

A5A1876..0 ⁱ

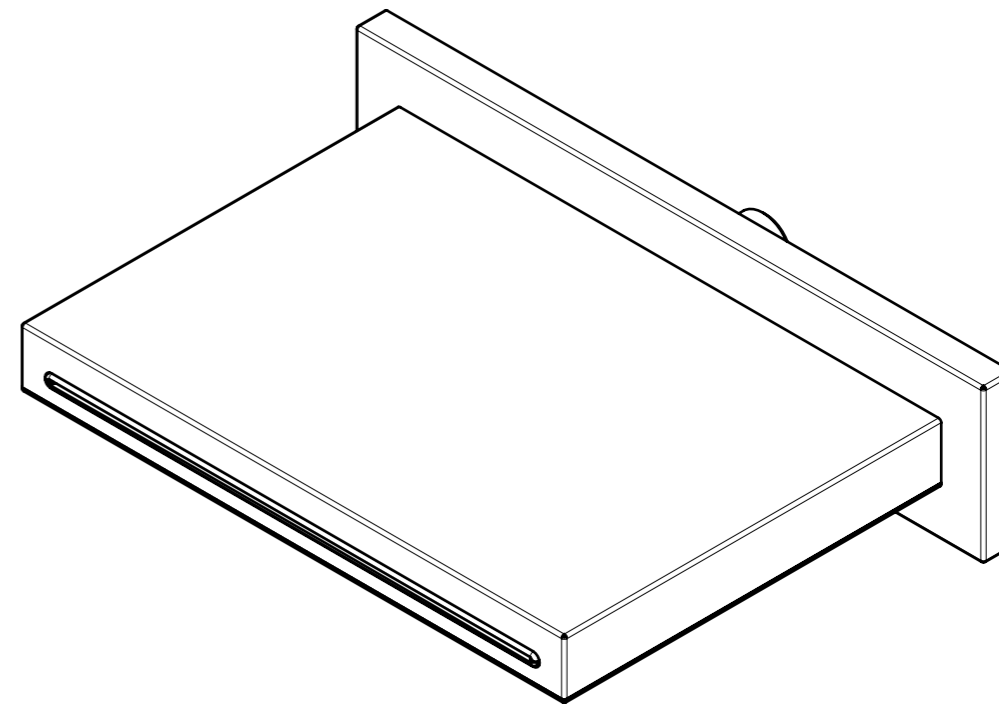
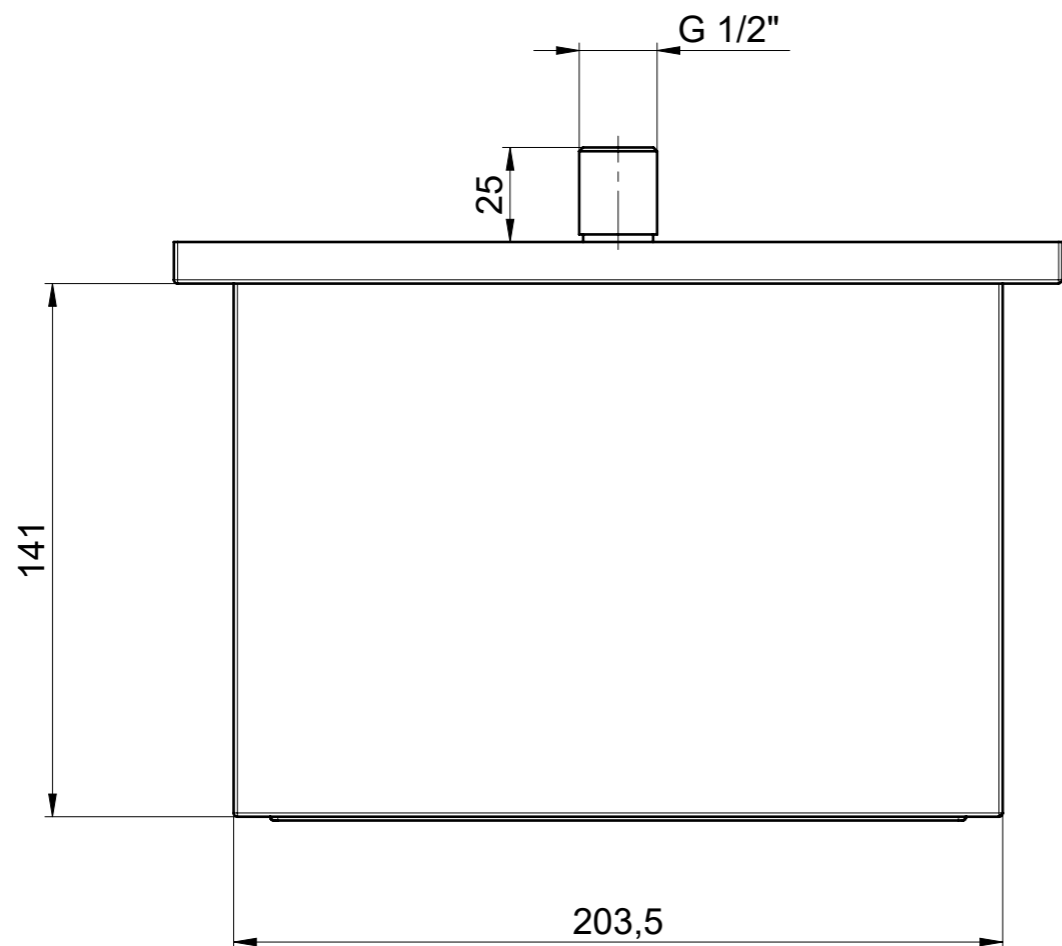
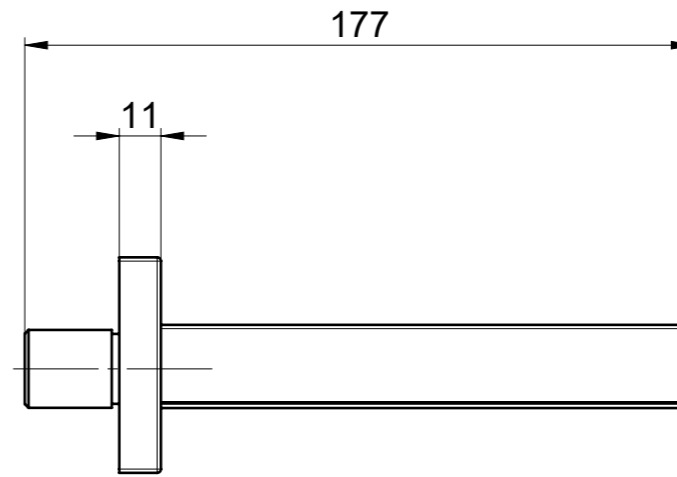
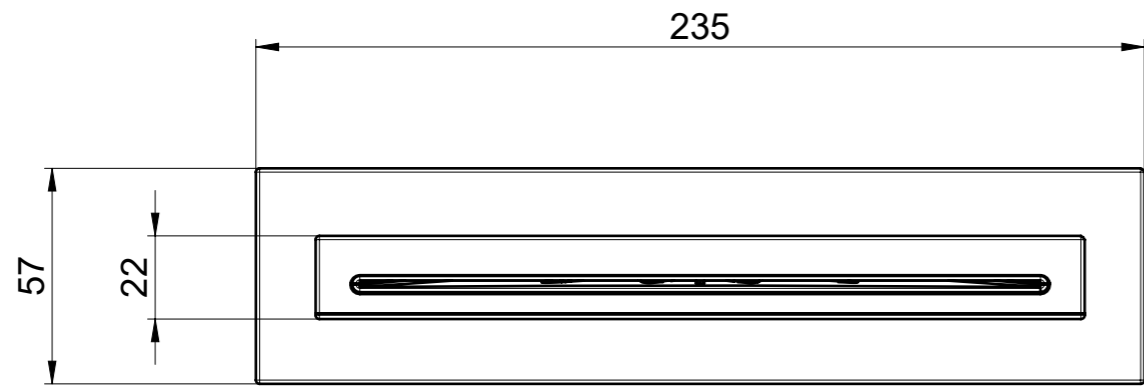

TOLERANCIAS A APLICAR CUANDO NO ESTA INDICADO. (Táchese la que no interese)
TOLERANCES TO APPLY IF NOT SPECIFIED. (Type what is not interested)

x ≤ 6	6 < x ≤ 30	30 < x ≤ 100	100 < x ≤ 300	300 < x ≤ 1000	1000 < x
±0,05	±0,1	±0,15	±0,2	±0,3	±0,5
±0,1	±0,2	±0,3	±0,5	±0,8	±1,2
±0,5	±0,5	±0,8	±1,2	±2	±3

SIGNOS SUPERFICIALES SIGNS SURFACES
3,2 / Mecanizado visible
0,8 / Mecanizado no visible
Sin trabajar
12,5 / Mecaniz. apreciable tacto

i	Add dimensions catalog sheet	20-11-04	JMRG	MATERIAL:	
Version	Modification	Date	Name	MATERIAL:	
Created by: Dibujado:	Date 12-10-03	Name JMRG		CAÑO Cascada AR CASCADE Shower AR	RDC
Checked by: Revisado:	Date 12-10-03	Name MOSCARDO			SCALE Escala 1:2
FINISHING: ACABADO:					VERSION I
WEIGHT: PESO:				ADRW-0005A1876	

